

GENERAL INFORMATION
 3RD ANGLE PROJECTION 
 DO NOT SCALE - IF IN DOUBT, ASK
 REMOVE ALL SHARP EDGES AND BURRS

ITEM NO.	PART NUMBER	DESCRIPTION	QTY.
1	LUM1469A	BESPOKE LR6 ROOFLIGHT OUTER FRAME GA	1
2	LUM1482A	BESPOKE LR6 ROOFLIGHT CASMENT GA	1
3	LUM0032P	HINGE WASHER	6
4	M8 Nylock Nut - ST STEEL	M8 NYLOCK NUT	3
5	ZA 85-1000 Side Mount Drive Assembly		2
6	M5 x 16 CSK POZI BZP SCREW		16
7	M5 DOME NUT		16

TOLERANCES UNLESS OTHERWISE SPECIFIED

LINEAR - 0 DECIMAL PLACES	±1.0mm
LINEAR - 1 DECIMAL PLACES	±0.50mm
LINEAR - 2 DECIMAL PLACES	±0.15mm
ANGULAR	±1.0°
SURFACE FINISH - GENERAL	3.2 µm
SURFACE FINISH - MACHINED	1.6 µm
SURFACE FINISH - GROUND	0.4 µm
SURFACE FINISH - POLISHED	0.2 µm
SCREW THREAD - INTERNAL	6H
SCREW THREAD - EXTERNAL	6g

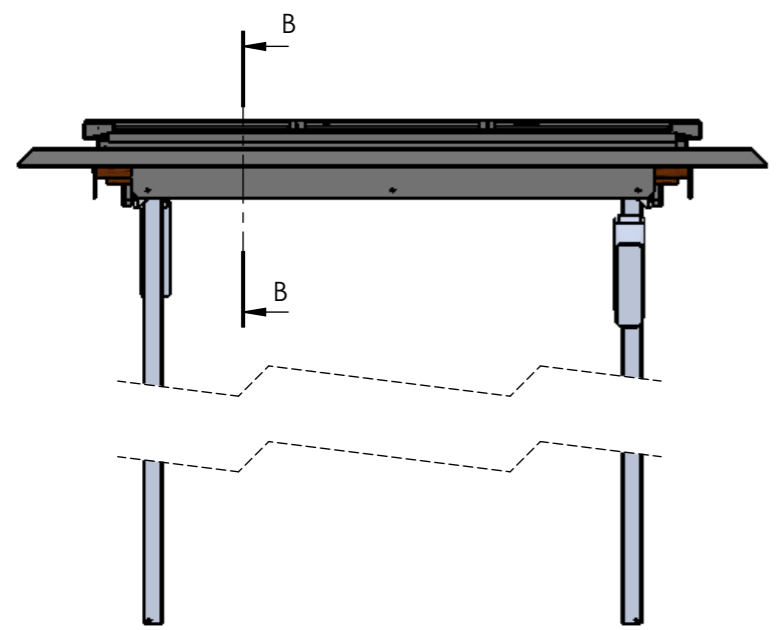
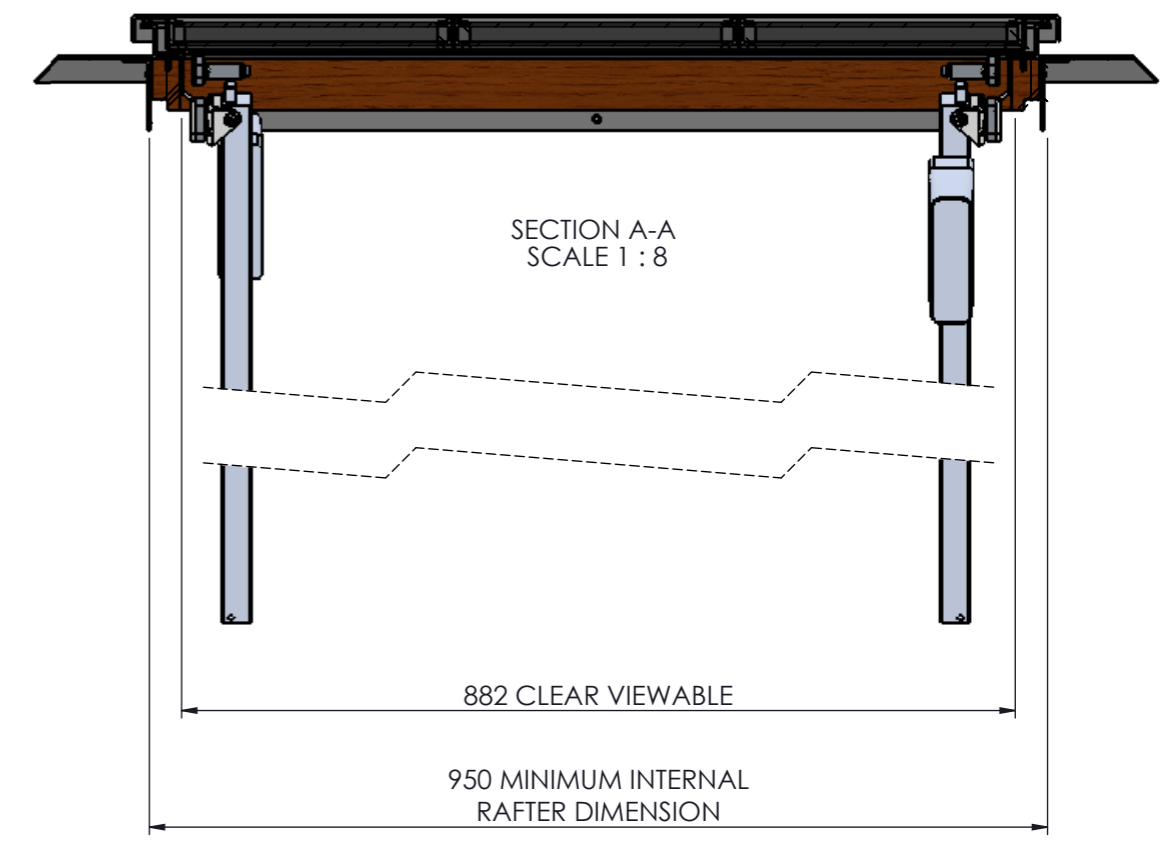
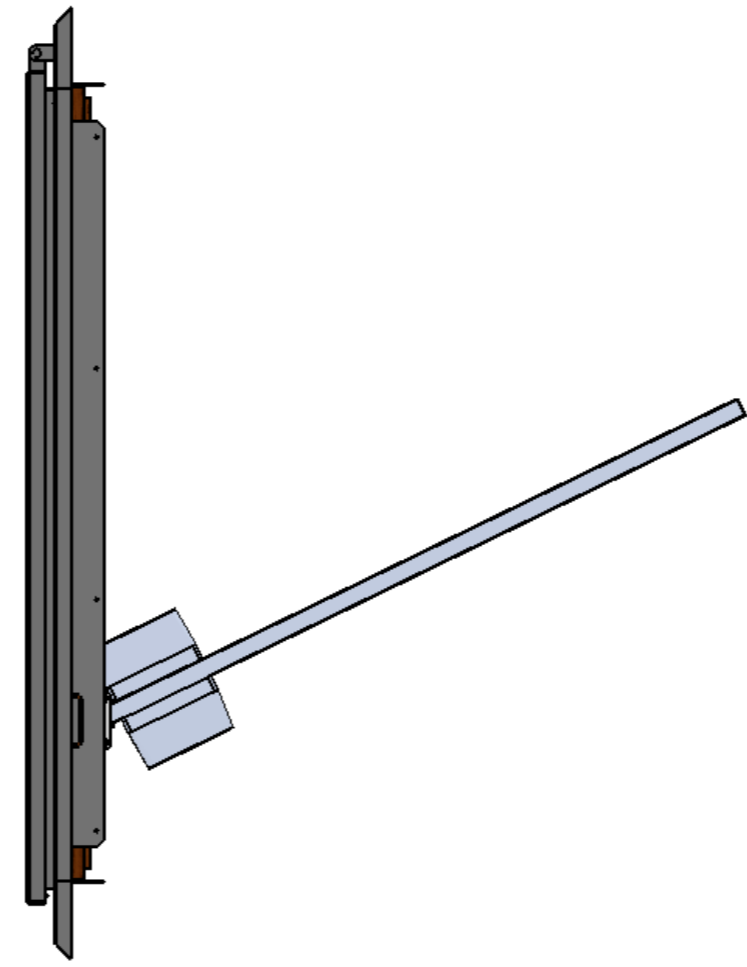
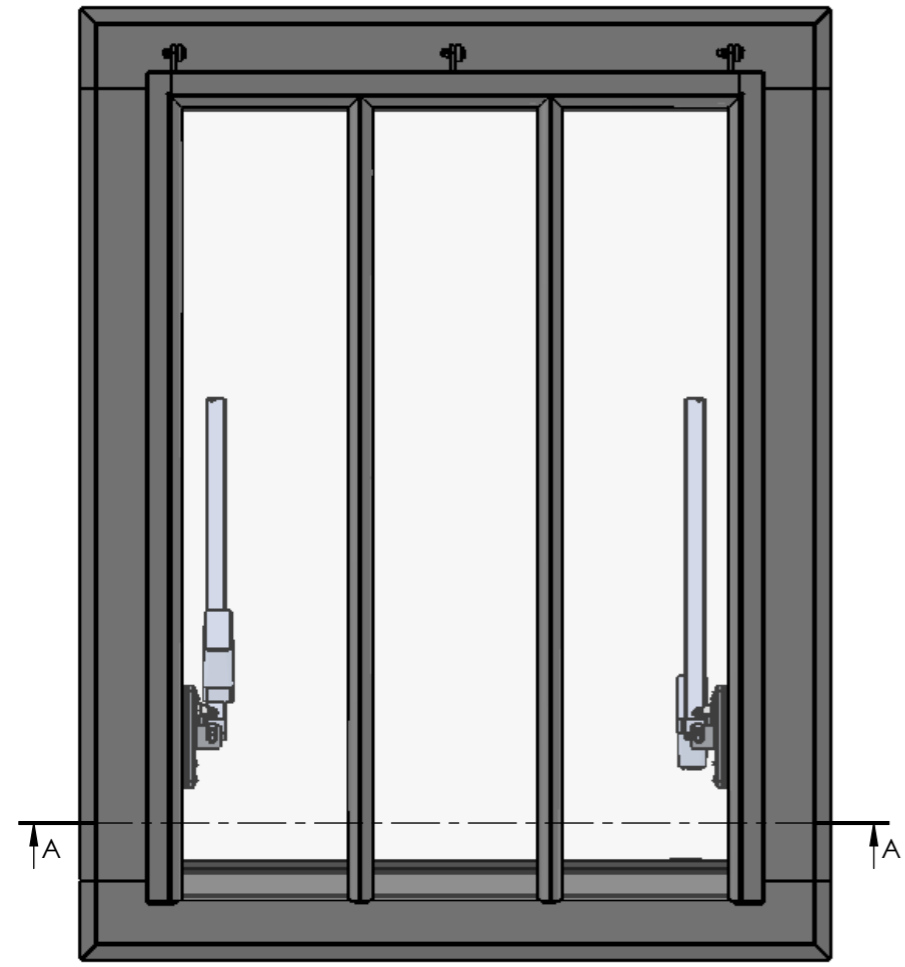

LUMEN
ROOFLIGHT

THE INFORMATION CONTAINED IN THIS DRAWING IS THE SOLE PROPERTY OF LUMEN. ANY REPRODUCTION IN PART OR AS A WHOLE WITHOUT WRITTEN PERMISSION IS STRICTLY PROHIBITED

SHEET: 1 OF 2 - A3
 DATE: 02/05/2014 UNITS: mm; kg

DRAWN: S.C
 SCALE: 1:12
 WEIGHT: 88.09

TITLE: BESPOKE AOV ROOFLIGHT GA

REF: 98-SISK SA. REF:

MATERIAL: MILD STEEL
 TREATMENT:
 FINISH: POWDER COAT RAL. 7015 SLATE GREY

PART TYPE: BESPOKE
 PART REF: LUM1468A

DRG. No. LUM1468A ISSUE: 2

GENERAL INFORMATION
 3RD ANGLE PROJECTION 
 DO NOT SCALE - IF IN DOUBT, ASK
 REMOVE ALL SHARP EDGES AND BURRS

TOLERANCES UNLESS OTHERWISE SPECIFIED	
LINEAR - 0 DECIMAL PLACES	±1.0mm
LINEAR - 1 DECIMAL PLACES	±0.50mm
LINEAR - 2 DECIMAL PLACES	±0.15mm
ANGULAR	
	±1.0°
SURFACE FINISH - GENERAL	
	3.2 µm
SURFACE FINISH - MACHINED	
	1.6 µm
SURFACE FINISH - GROUND	
	0.4 µm
SURFACE FINISH - POLISHED	
	0.2 µm
SCREW THREAD - INTERNAL	
	6H
SCREW THREAD - EXTERNAL	
	6g

CROSS SECTION OF ROOFLIGHT SHOWN IN ITS FULLY OPEN POSITION

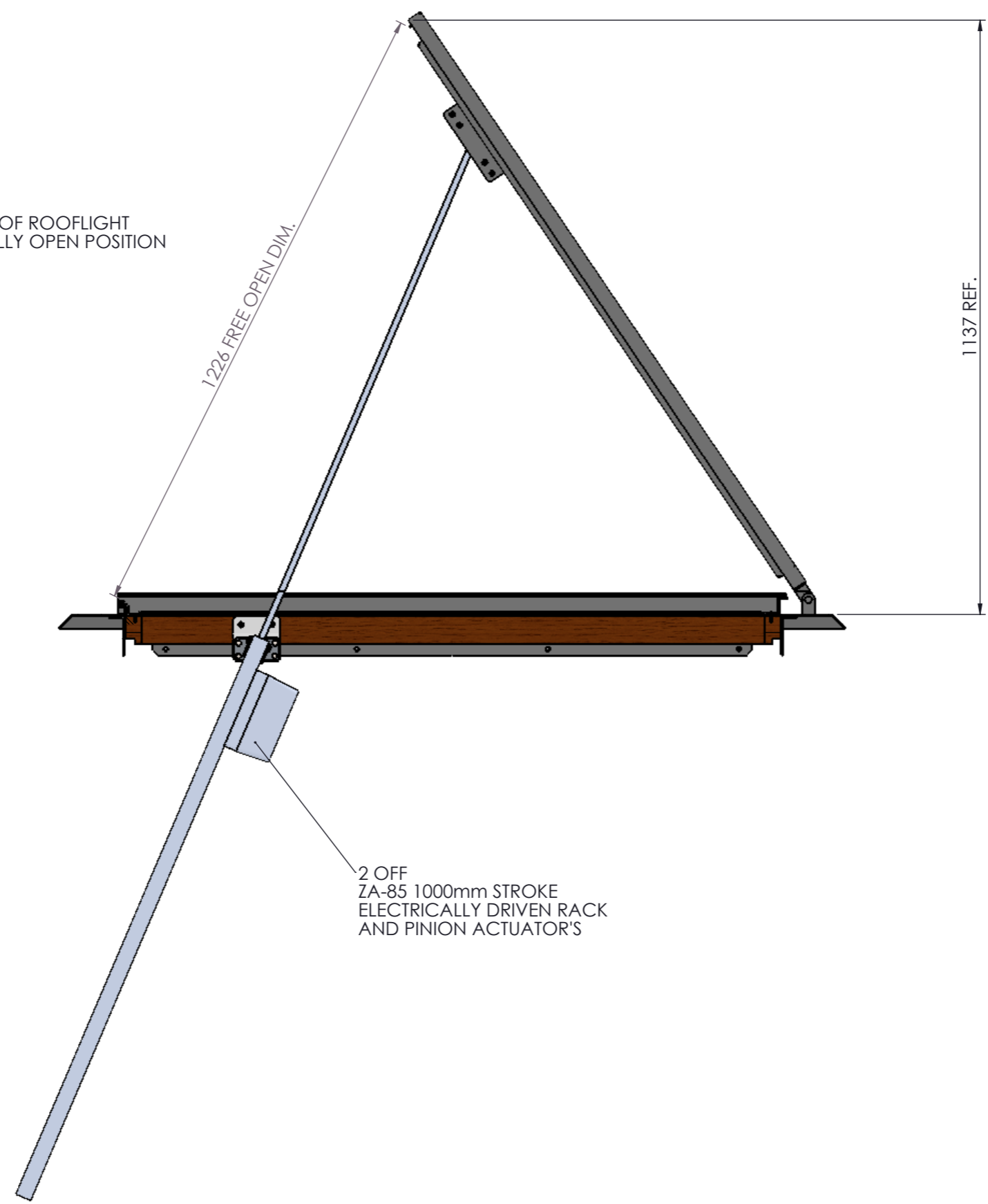

2 OFF
 ZA-85 1000mm STROKE
 ELECTRICALLY DRIVEN RACK
 AND PINION ACTUATOR'S

LUMEN
 ROOFLIGHT

THE INFORMATION CONTAINED IN THIS DRAWING IS THE SOLE PROPERTY OF LUMEN.
 ANY REPRODUCTION IN PART OR AS A WHOLE WITHOUT WRITTEN PERMISSION IS STRICTLY PROHIBITED

SHEET: 2 OF 2 - A3
 DATE: 02/05/2014 UNITS: mm; kg

DRAWN: S.C
 SCALE: 1:10
 WEIGHT: 88.87

TITLE: BESPOKE AOV ROOFLIGHT GA
 REF: 98-SISK SA. REF:

MATERIAL: MILD STEEL
 TREATMENT:
 FINISH: POWDER COAT RAL. 7015 SLATE GREY

PART TYPE: BESPOKE
 PART REF: LUM1468A
 DRG. No. LUM1468A ISSUE: 2